

IT - ISTRUZIONI DI MONTAGGIO
EN - ASSEMBLY INSTRUCTIONS
DE - INSTALLATIONSANLEITUNG
FR - INSTRUCTIONS DE MONTAGE

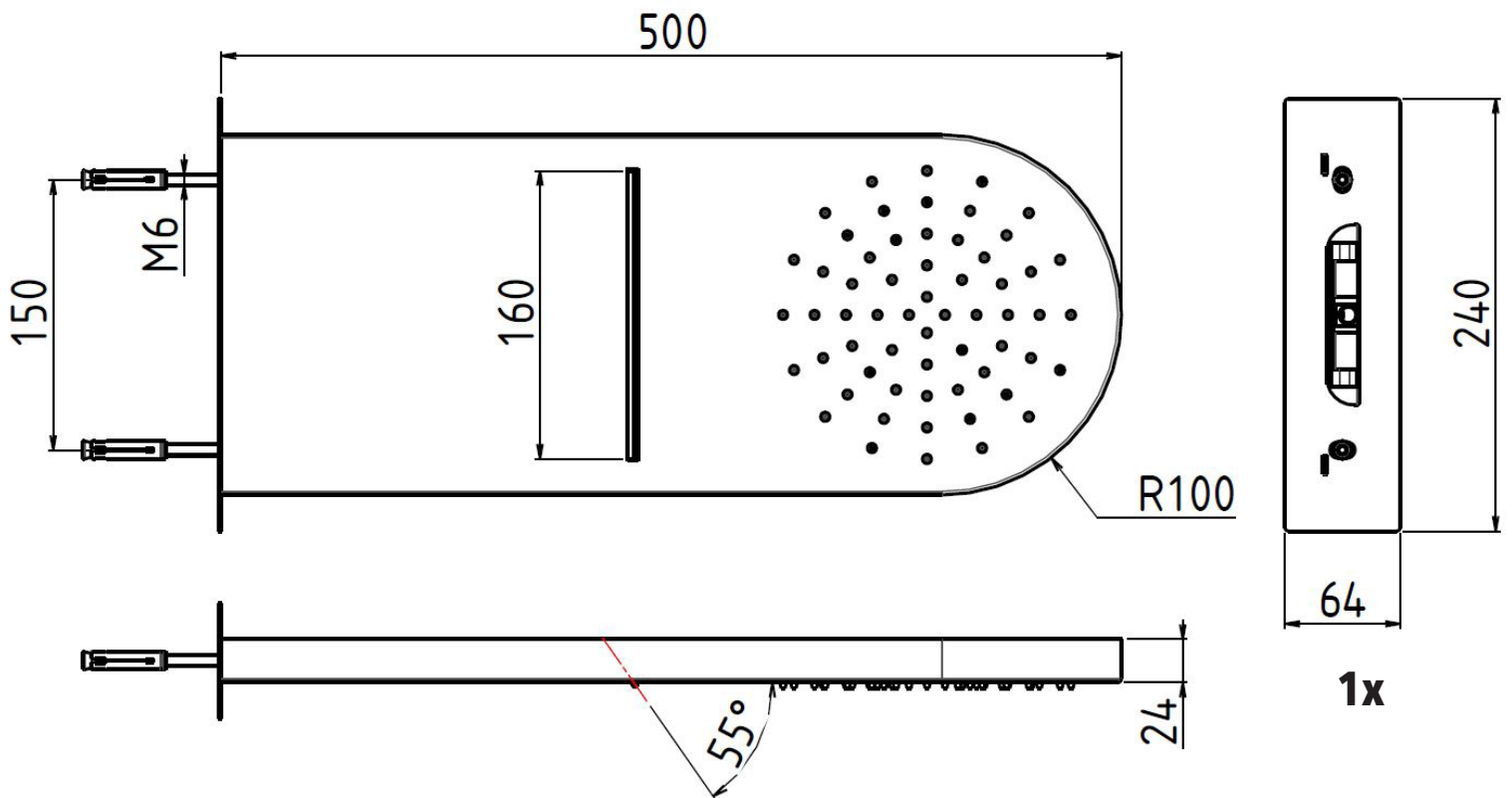

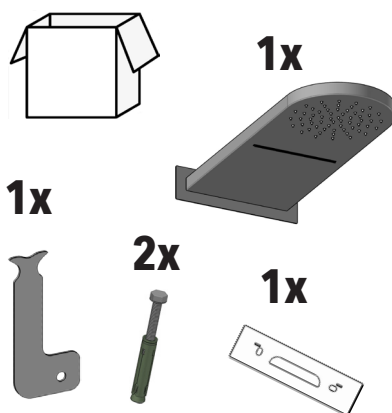

IT - Prima dell'installazione.
EN - Before installation.
DE - Vor der Installation.
FR - Avant l'installation



IT - Già montati sul soffione.
EN - Already mounted on the shower head.
DE - Bereits am Duschkopf montiert.
FR - Déjà monté sur la pomme de douche.

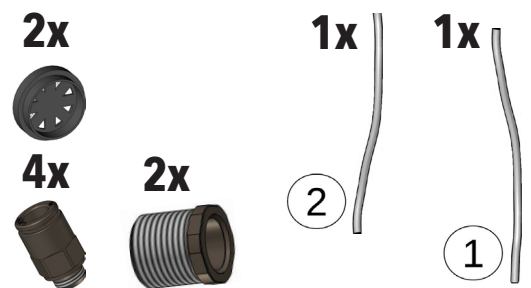

IT - L'apparecchio deve essere installato da personale abilitato ai sensi e per l'effetto delle leggi in vigore.

EN - According to the law, all installation and maintenance operations require a qualified person.

DE - Das Gerät muss von qualifiziertem Personal gemäß den geltenden Gesetzen installiert werden.

FR - L'appareil doit être installé par du personnel qualifié conformément et pour l'effet des lois en vigueur.

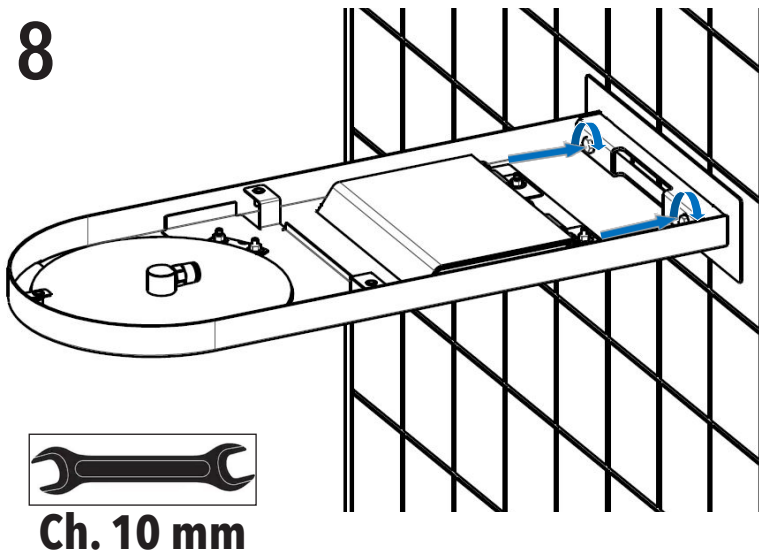
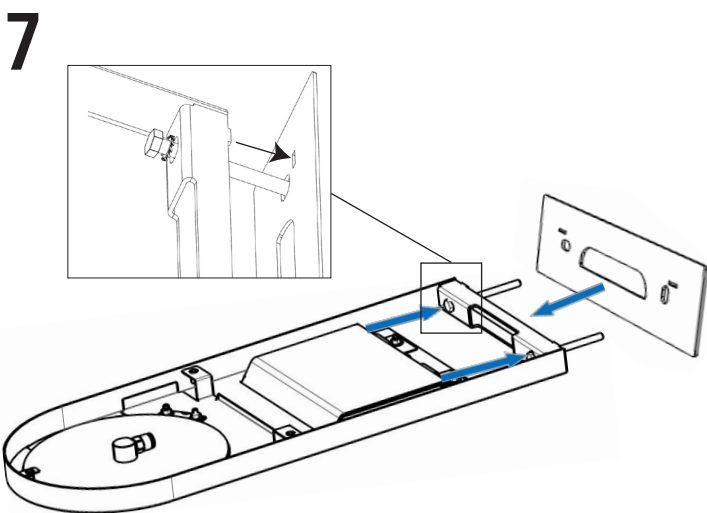
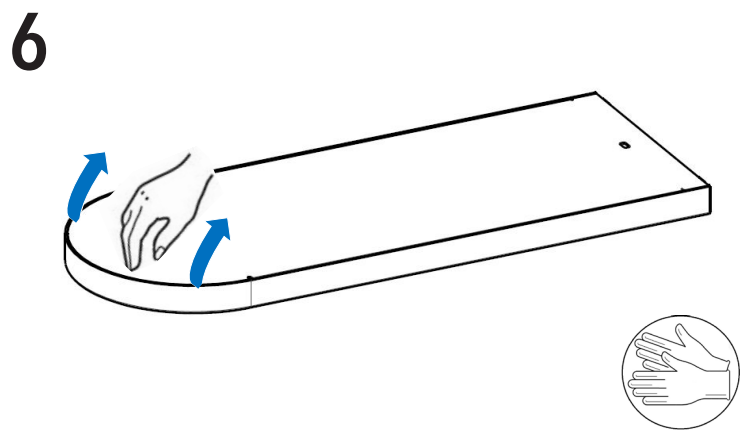
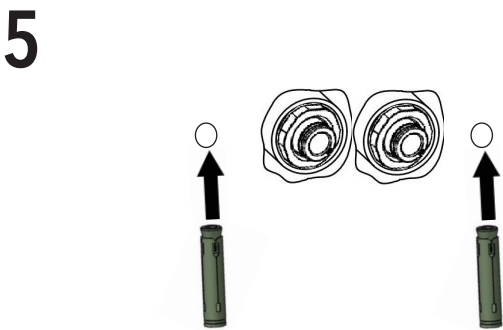
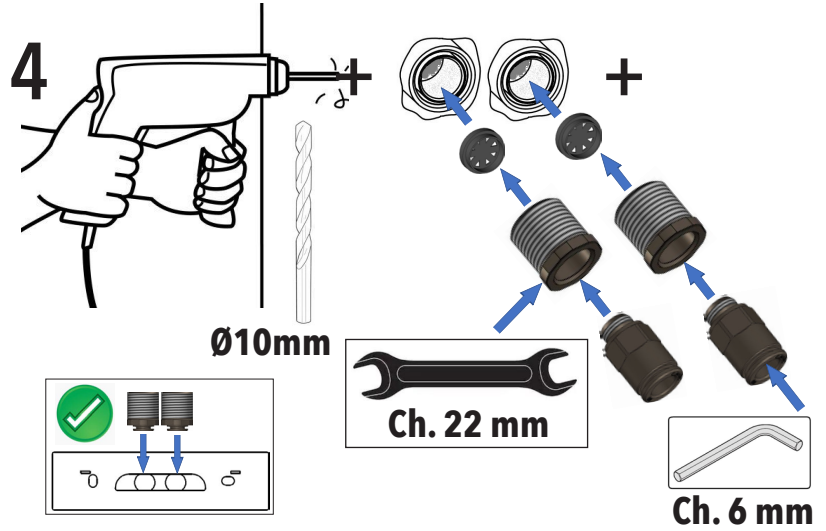
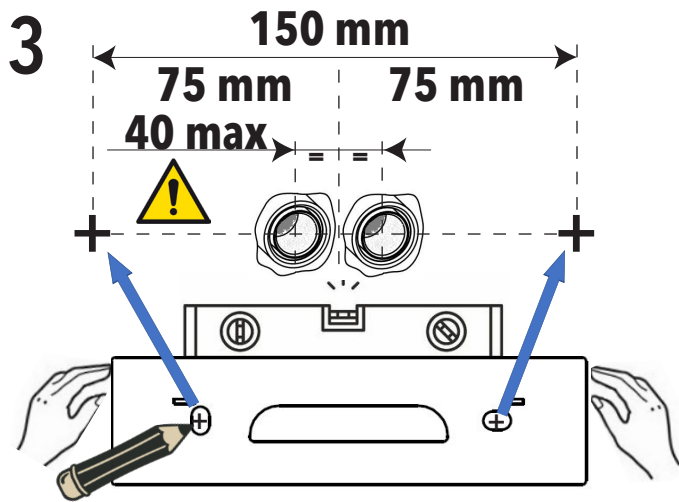
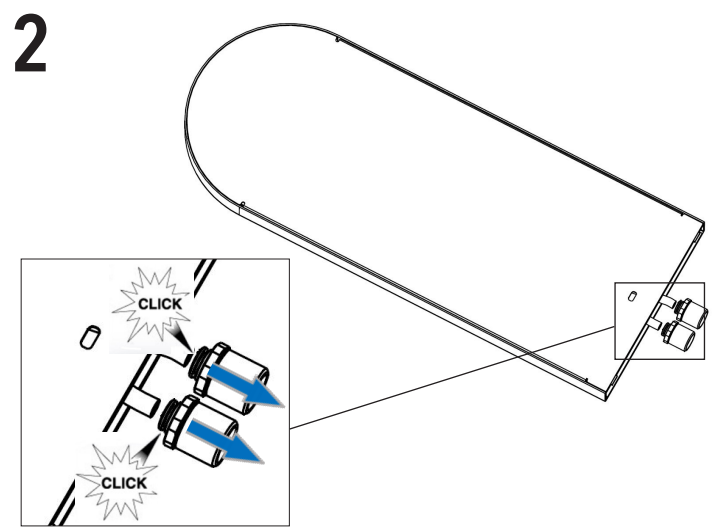
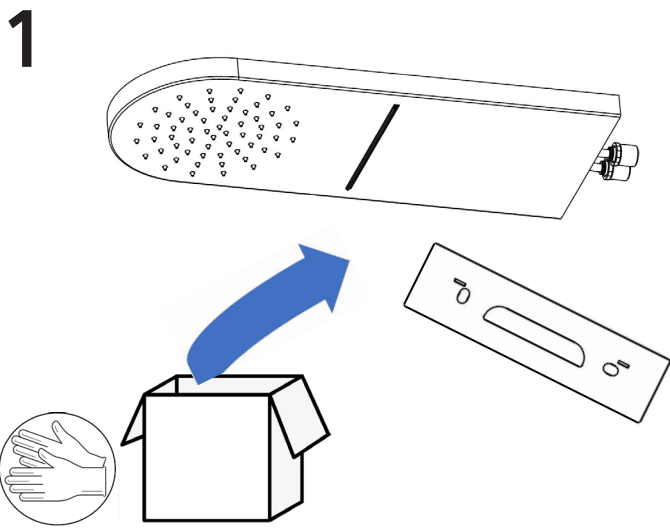

9

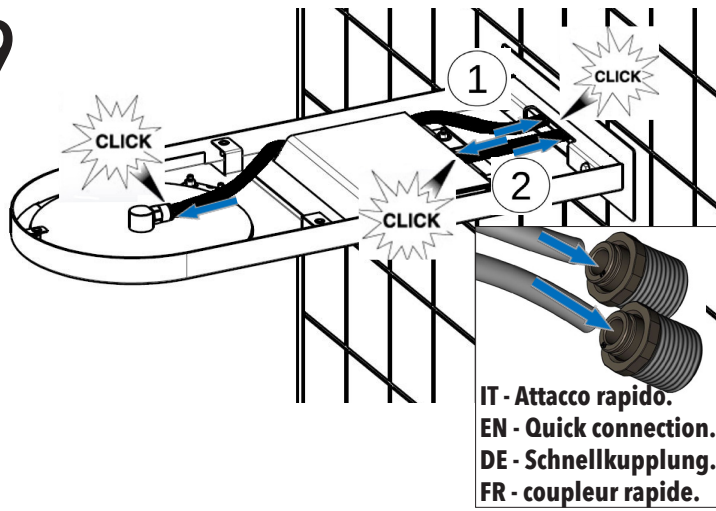

10

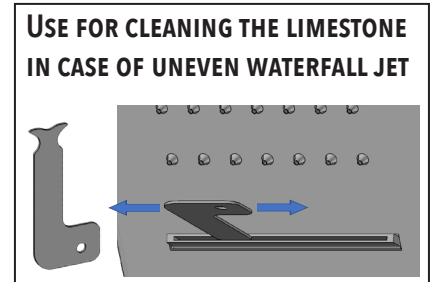
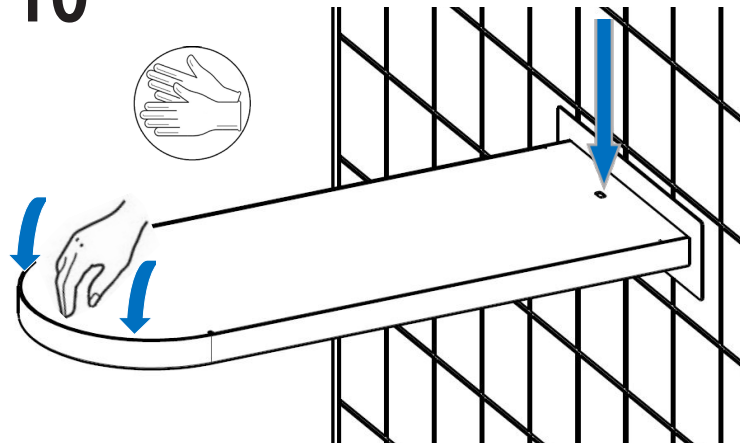

✗ IT - LA GARANZIA DEL PRODOTTO NON COPRE
L'utilizzo improprio.

L'errata predisposizione dell'impianto idraulico.
Danni causati da depositi di calcare o altre impurità.
Detergenti non adatti.

EN - NOT COVERED BY PRODUCT CARE

Not correct use.
Incorrect setup of the hydraulic system.
Water impurities or limeston.
Not suitable detergents.

DE - DIE PRODUKTGARANTIE DECKT NICHT AB

Fehlerhafte Verwendung.
Die falsche Anordnung des Hydrauliksystems.
Schäden durch Kalkablagerungen oder andere Verunreinigungen.
Ungeeignete Reiniger.

FR - LA GARANTIE DU PRODUIT NE COUVRE PAS

Utilisation incorrecte.
La mauvaise disposition du système hydraulique.
Dommages causés par des dépôts de calcaire ou d'autres impuretés.
Nettoyants inappropriés.

✓ IT - DUE ANNI DI GARANZIA DEL PRODOTTO
Contro i difetti o vizi di fabbricazione.

EN - TWO-YEAR PRODUCT CARE
Against defects or defects of fabrication.

DE - ZWEI JAHRE PRODUKTGARANTIE
Gegen Mängel oder Herstellungsfehler

FR - GARANTIE DE PRODUITS DE DEUX ANS
Contre les défauts de fabrication ou les défauts.

IT - ATTENZIONE: Si declina ogni responsabilità relativa ad eventuali inesattezze contenute in queste istruzioni dovute ad errori di trascrizione.

EN - WARNING: We decline all responsibility and eventual inaccuracy contained in the instructions due to transcript errors.

DE - ACHTUNG: Wir lehnen jede Verantwortung für Ungenauigkeiten in diesen Anweisungen aufgrund von Transkriptionsfehlern ab.

FR - ATTENTION: Nous déclinons toute responsabilité pour toute inexactitude contenue dans ces instructions en raison d'erreurs de transcription.